



INSTALLATION INSTRUCTIONS

Accessory
FABRIC ROOF/REAR PANEL
 P/N 0SR85-HL5-A01B (BLACK)
 P/N 0SR85-HL5-A02C (CAMO)

Application
SXS520M2

Publication No.
MII 17623
 Issue Date
December 2020

Honda Dealer: Please give a copy of these instructions to your customer.

PARTS LIST

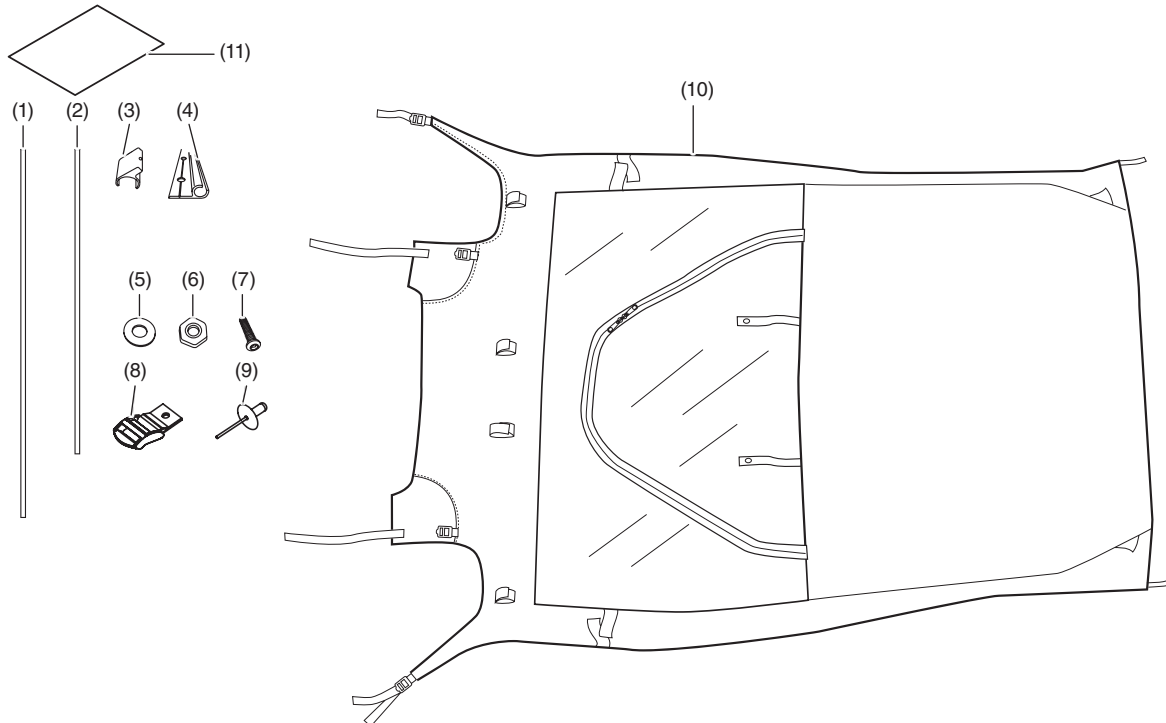

No.	Description	Qty
(1)	Long fiber rod	2
(2)	Short fiber rod	2
(3)	Bar snap	4
(4)	P-channel	1
(5)	6 mm washer	10
(6)	6 mm nut	5
(7)	6 mm x 20 mm Round Head bolt	5
(8)	Webbing/buckle attachment	2
(9)	3/16 Large Flange Rivet	2
(10)	Fabric roof/rear panel	1
(11)	Installation Instructions URL	1

TOOLS AND SUPPLIES REQUIRED

- Gloves
- Safety Goggles
- Power drill
- Drill bit (6 mm or ¼ inch)
- Drill bit (5 mm or 13/64 inch) – only if installing with accessory doors
- Socket (10 mm)
- Ratchet
- Allen Wrench (4 mm)
- Rivet installation tool – only if installing with accessory doors

TORQUE CHART

Tighten all screws, bolts, and nuts to their specified torque values. Refer to the Service Manual for the Torque values of the removed parts.

Item	N-m	kgf-m	lbf-ft
6 mm bolt/nut	5.6	0.55	4.1

USE AND CARE INFORMATION

- Do not tow the vehicle uncovered on an open trailer with this accessory installed, as the accessory is not designed for use at highway speeds.
- To clean, sponge with mild soap and cold water, rinse with a hose and allow it to drip-dry.
- Do not machine wash or dry.
- Use mild detergent to remove stubborn stains.
- The rear window can be rolled up and stowed using the webbing straps and snaps.
- When not in use, the window roll-up webbing straps can be fastened to themselves using the snaps.
- Do not force the zipper on the rear window. In case of a jam, unzip and remove any obstructions. If problems persist, the zipper must be cleaned.
- The zipper should be cleaned using a toothbrush with soap and water and rinsed as needed to keep it free of dust and dirt. Once the zipper is cleaned, the teeth should be lubricated using beeswax.
- This accessory will create the need for more frequent air cleaner maintenance. Service the air cleaner daily when operating in dusty conditions.

INSTALLATION

NOTE:

A full Poly Windscreen is required for the installation of this accessory. If the windscreen is already installed the clamps will need to be loosened prior to installation of this accessory. If the accessory doors will be installed with the fabric roof/rear panel, the front shrouds will need to be removed prior to installation of this accessory and reinstalled according to the instructions below. If the accessory doors will not be installed with the fabric roof/rear panel the webbing/buckle attachments and rivets will not be used at this time.

1. Refer to the Service Manual for the vehicle, remove the seat back and seat from the vehicle. Unhook the upper rear net attachment point.

2. Align the P-channel against the top edge of the windscreen with its opening facing down as shown. Position the top edge of the P-channel 1-1/8" from the top bend of the windscreen and center it side to side. Using the holes in the P-channel as a guide, drill five 6 mm holes in the windscreen. Clean and de-burr the holes.

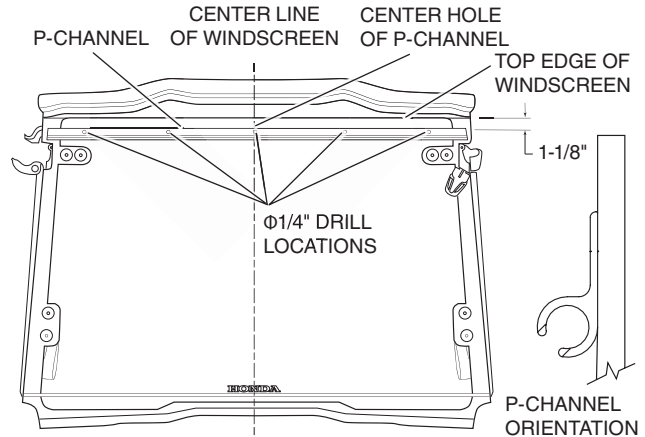

3. Install the P-channel using the 6 mm hardware provided, with each bolt and one washer inserted from the outside and with another washer and each nut installed from the inside of the windscreen. Once the P-channel has been installed, reinstall the windscreen to the vehicle. Do not fasten the upper windscreen clamps at this time.

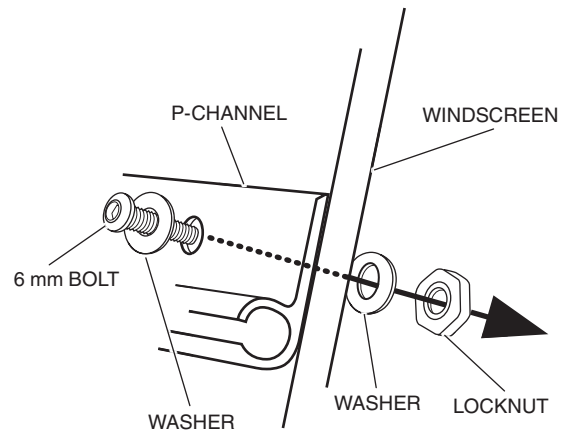

4. Install the long fiber rod into the fabric pocket as shown on both sides.

CAUTION

To prevent eye injuries, wear eye protection when handling the fiber rods. To prevent injuries from splinters, wear protective gloves when handling the fiber rods.

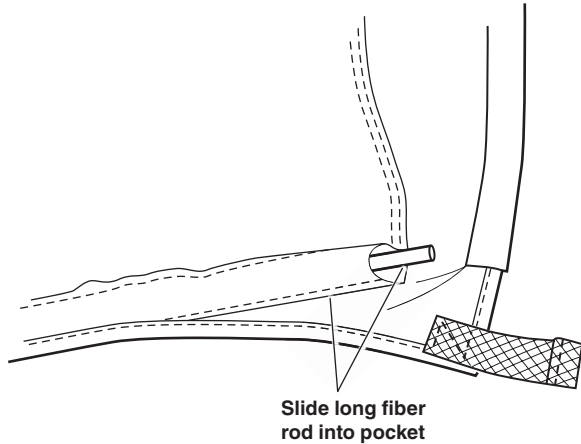

5. Insert the short fiber rod into both bar snaps. Attach bar snap onto rear OPS tube and rotate to snap front bar snap onto front OPS tube. Locate front bar snap 11" from side OPS tube and locate rear bar snaps 12" from side OPS tube. Repeat for other side.

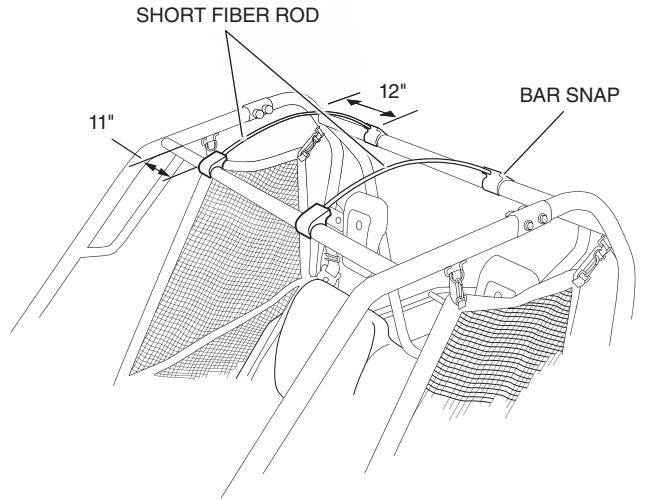
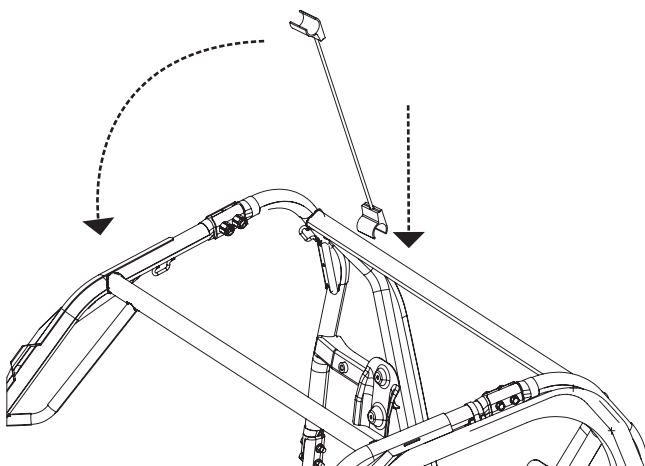
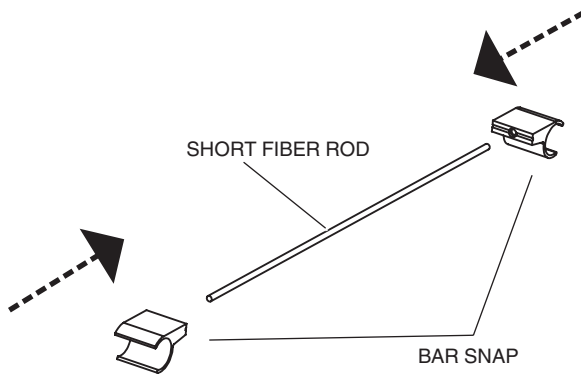

6. Install the fabric roof/rear panel to the P-channel by draping it over the front of the vehicle with cover rod pockets face up and slide the welting on the front edge of cover through the opening in either end of the P-channel.

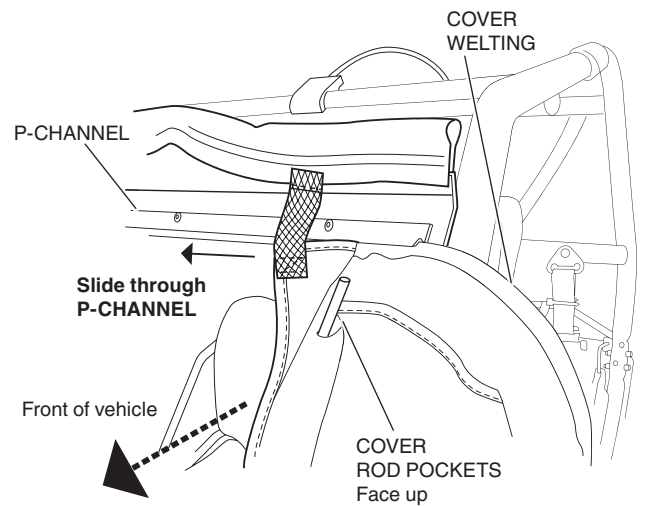

7. Flip the fabric roof/rear panel over the windscreen so that it drapes over the vehicle OPS.

For the following steps:

If installing without doors, use step 8.

If installing with doors, use steps 9-12.

Then continue with step 13 for all.

- Pull the front webbing strap under the upper windscreen clamp and close the clamp. Make sure that the fabric roof/rear panel is centered evenly from side to side.

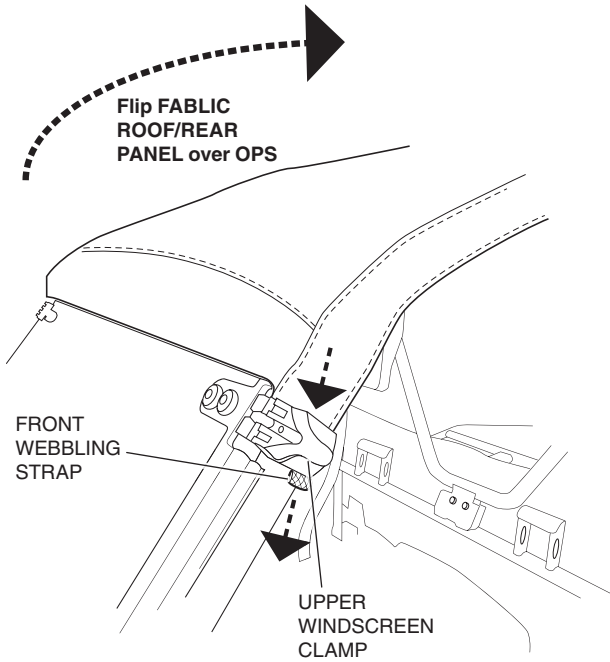

- If installing with the accessory doors: Remove the door shrouds. Drill a 5 mm (13/64") hole in each, centered on the bottom face of the windscreen upper lamp location, as shown.

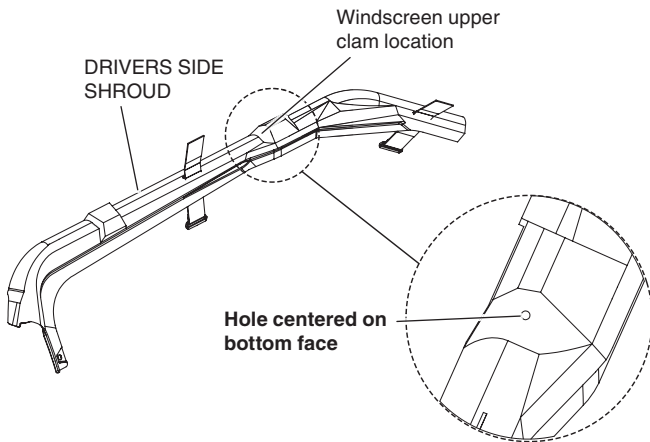

- Attach a webbing/buckle attachment through the drilled hole in each shroud, with a large flange rivet, as shown.

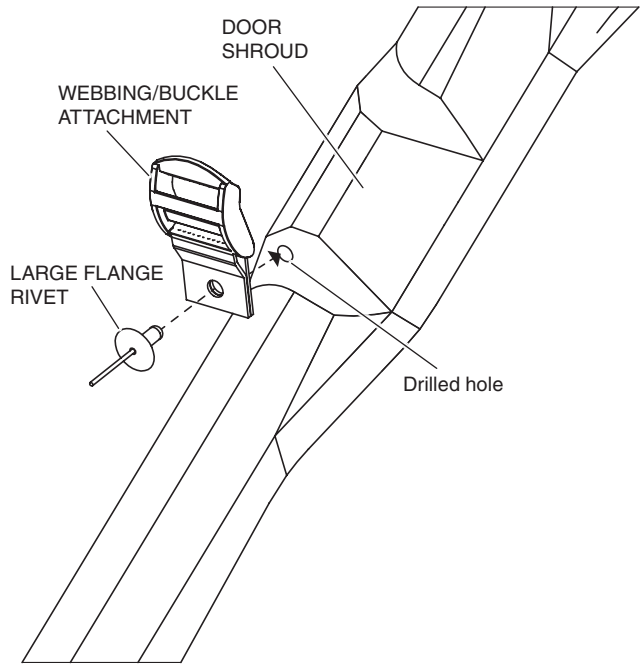

- Reinstall the door shrouds according to the accessory door installation instructions.
- Thread the fabric roof/rear panel front webbing strap through the buckle. Repeat for other side. Do not fully tighten at this time.

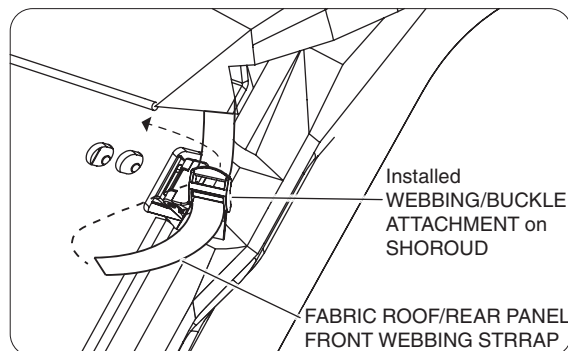
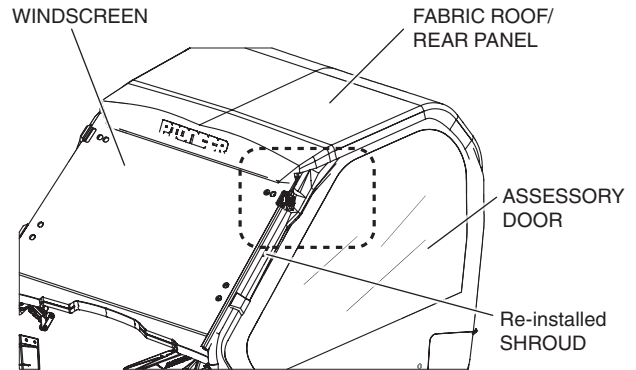

13. Tilt the bottom of the windscreen up. The top of the wind screen will move backwards to relieve tension on the cover. This will ease the rest of the installation process.

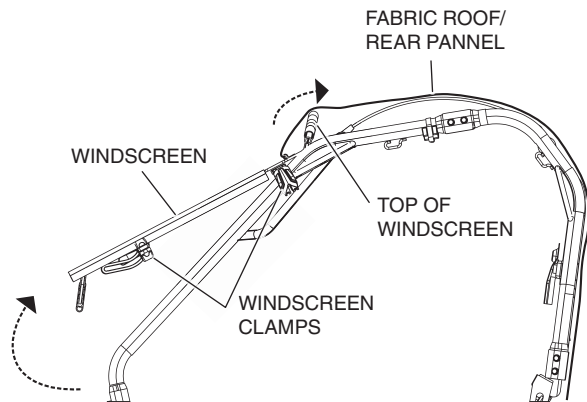

14. Remove the lower outer webbing strap from the lower ladder lock buckle. Wrap the webbing strap around the lower OPS tubes and back through the loop on the end of the webbing strap. Thread the end through the ladder lock buckle. Repeat for the other side. Do not fully tighten the straps at this time.

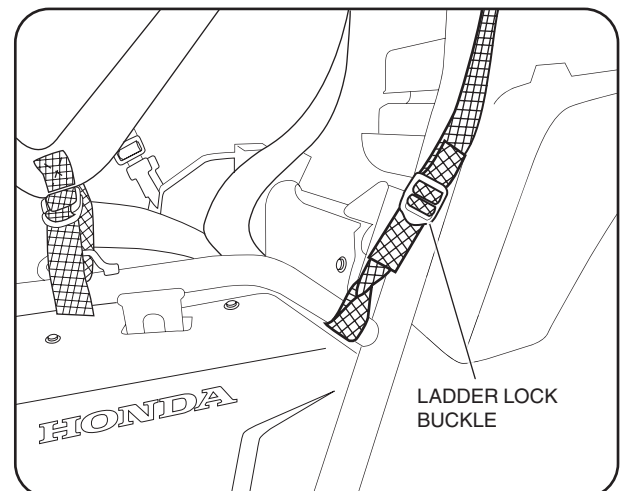
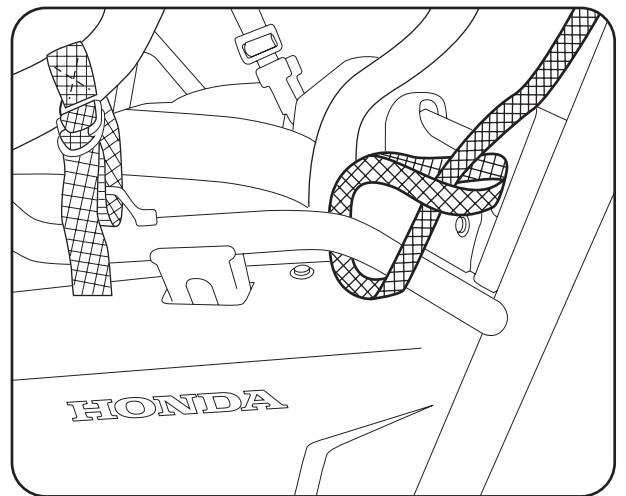
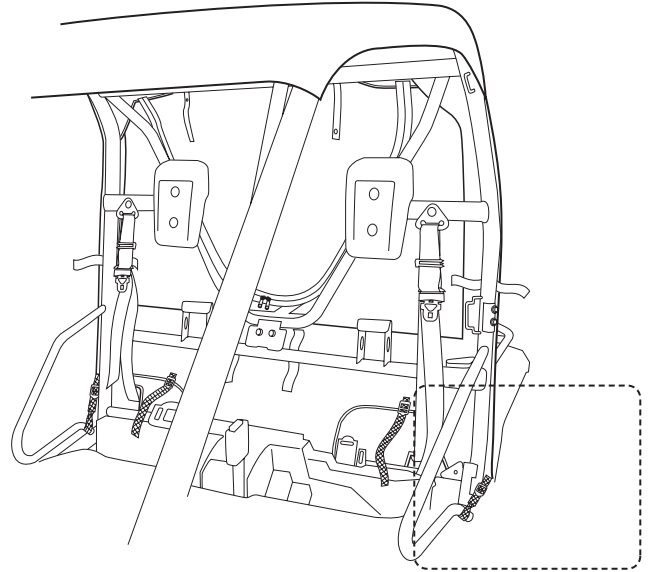

15. From the inside of the vehicle, wrap the lower inner webbing strap around the lower horizontal OPS tube, and then up through the ladder lock buckle. Repeat for the other side.

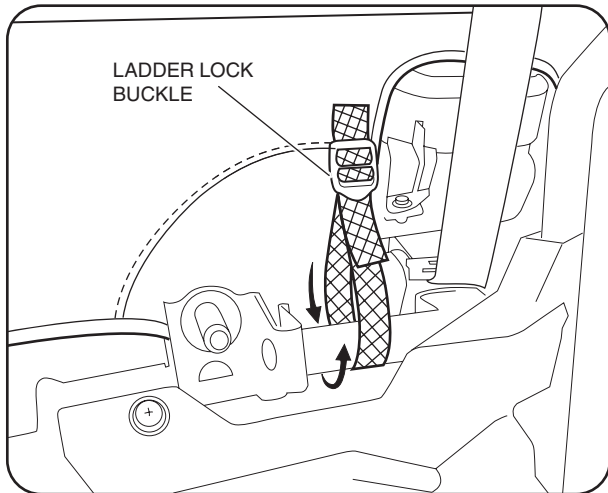
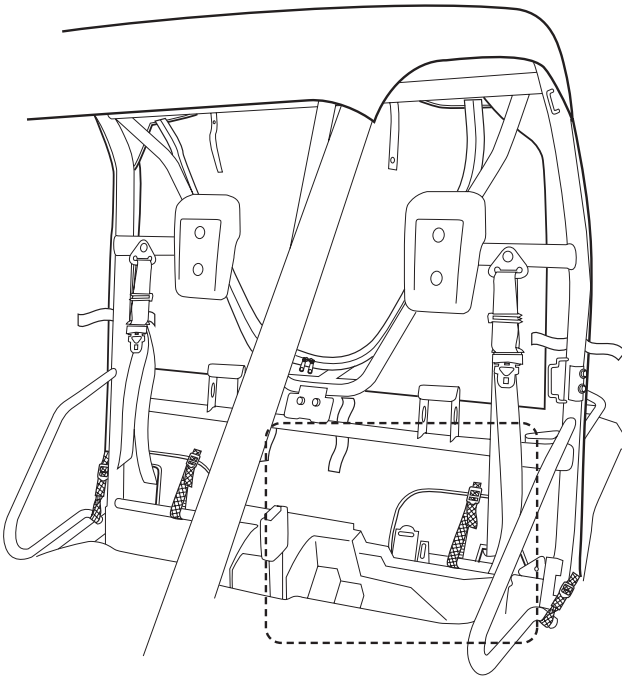

16. Tighten all of the webbing straps evenly. The top of the rear window should be even with the upper horizontal OPS tube. The bottom of the rear window should be pulled tight.

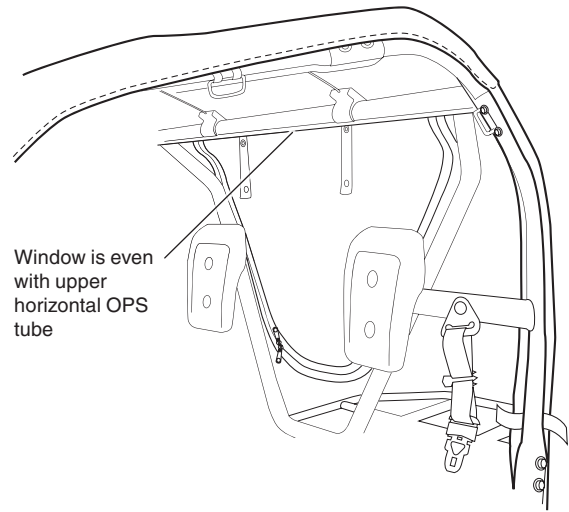

17. From the inside of the vehicle, tightly wrap the hook and loop straps around the vertical OPS tubes. Tightly wrap the hook and loop straps around the lower horizontal OPS tube.

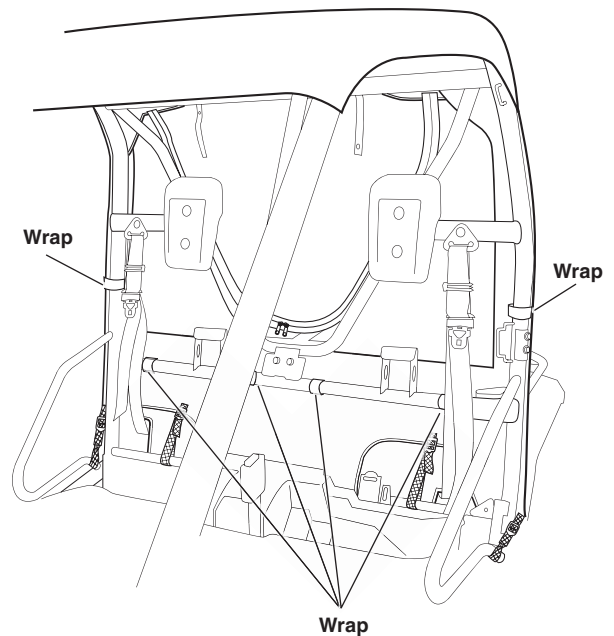

18. To ensure a tight fit after tightening rear straps, tilt the windscreen down and lock it in that closed position. The top of the wind screen will move forward and tension the cover to ensure a tight fit.

